

**NYE- TRAY WET SCRUBBER**  
**VENTURI WET SCRUBBER**  
**CYCLO VENTURI SCRUBBER**

The **ENMILL** Nye Tray & Venturi Scrubber are the most advanced state of the art, cost effective technology for removing micron size particulate matters from the flue gases coming out of Bio-mass (Bagasse, Rice- Husk, Cane Trash etc.) and other fuel like Bio-gas, Coal etc. fired in Boilers.



Clean gas from Wet Scrubbing System

**OUR SCRUBBER PROVIDES**

- High Reliability
- Low Draught Loss
- No Water Carry Over
- Low Construction Cost
- Simple Operation
- High Efficiency to meet Pollution Norms
- Absorption of eco un-friendly gases
- Mechanised Slurry Dewatering System



Venturi Scrubber under installation



Nye Tray Wet Scrubber with RCC Clarifier and Mechanized Slurry Handling at one Sugar unit



Cyclo Venturi Scrubber at one of the Sugar mills

**SOME OF OUR USERS**

- Kesar Enterprises Ltd.
  - Balrampur Chini Mills Ltd.
  - Sakthi Sugar Ltd.
  - Bajaj Hindusthan Ltd.
  - ISGEC Heavy Engineering Ltd.
  - U.P. Sugar Co. Ltd., Kushinagar
  - Walchandnagar Industries Ltd.
  - Petra Boilers Sdm Bhd., Malaysia
  - U.P.Sugar Co-op. Ltd.: KayamGanj Satha Belrayam Rudrabilas Ghosi
  - DSM Sugars Ltd.
  - Olam Agro India Ltd.
  - Rosa Sugar Works Ltd.
  - L.H Sugar Factories Ltd.
  - Tendaho Sugar, Ethiopia  
Project: Chemical System Technologies Walchandnagar Industries Ltd.
  - Indian Potash Ltd.
  - PT SMIP, Indonesia  
Project: Chemical System Technologies ISGEC Heavy Engineering Ltd.
  - PT PNS, Indonesia  
Project: Chemical System Technologies ISGEC Heavy Engineering Ltd.
  - PT DUS, Indonesia  
Project: Chemical System Technologies
- Client: Batliboi Environment Energy Ltd.

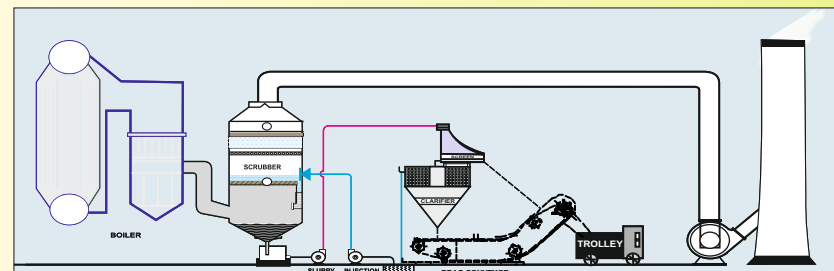

NYE TRAY WET SCRUBBER WITH MECHANISED SLURRY DEWATERING SYSTEM

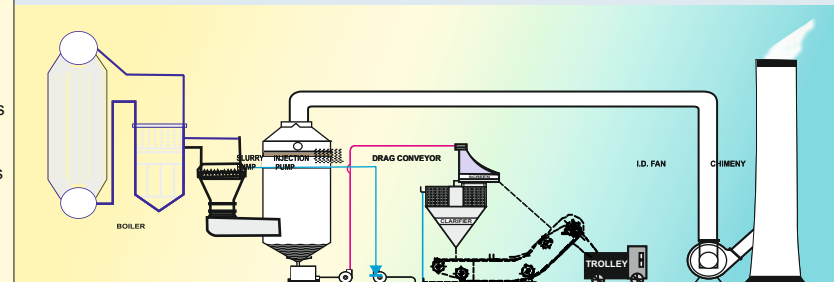

VENTURI TYPE WET SCRUBBER WITH MECHANISED SLURRY DEWATERING SYSTEM

**ENMILL TECHNOLOGIES**

Enmill Works, Plot No. B-2/24, Site - B, UPSIDC Surajpur Industrial Area, Greater Noida (U.P.) - 201306 India. Phones : 0120-2560134, 0120-4338468  
E-mail : enmill@gmail.com

**TWO ROLLER ENMILL EXTRACTION MILL**  
**TWO ROLLER ENMILL EXTRACTION MILL WITH PRESSURE FEEDER SYSTEM**

The Two Roller **ENMILL** Extraction Mill is the state of the art, energy efficient and cost effective technology for achieving substantial increase in crushing capacity and efficiency.



40''X80'' Two Roller Enmill Extraction Mill Installed at IJT-HPCL Biofuels Ltd., Sugauli & Lauriya (Bihar)

- High Crushing Capacity
- High Extraction Efficiency
- Low Power Consumption
- Low Maintenance
- High Imbibition Efficiency
- Differential Speed of Rollers
- Hydraulically Loaded Top Roller
- Flexibility for Further Expansion
- Re-absorption Control Device
- Automation
- Less Investment-High Returns

**Energy Saving : 25% (+)**  
**Extraction : 72% (+)**  
**Moisture in Bagasse : 49% (-)**

**OUR INSTALLATIONS**

- J. K. Sugar Ltd., Bareilly, (UP)
- Kesar Enterprises Ltd., Bareilly, (UP)
- Sagar Sugar & Allied Products Ltd., Chittoor, (AP)
- IJT-HPCL Biofuels Ltd., Sugauli, (Bihar)
- IJT- HPCL Biofuels Ltd., Lauriya (Bihar)
- Bindal Papers Ltd., Muzaffarnagar, (UP)
- K.R Pulp & Paper Ltd., Shahjahanpur, (UP)

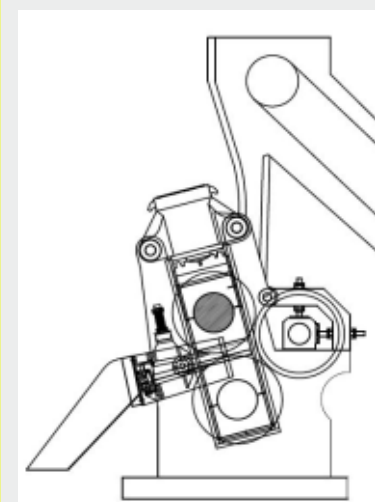

Two Roller Enmill Extraction Mill



Two Roller Enmill Extraction Mill In Operation



## MILLING DIVISION

### Grooved Roller Pressure Feeder (GRPF) Toothed Roller Pressure Feeder (TRPF)

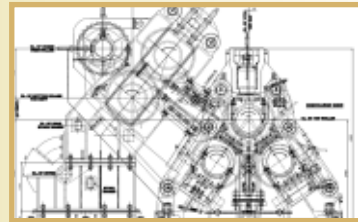

- Improves Juice extraction of a mill by 20%
- Shaft Mounted planetary Gear Drive
- Independent Foot Mounted Planetary Gear Drive
- Triplex Chain Drive
- Pressure Feeding to Mill

### Toothed Under Feed Roller (TUFR)

- Pressure Feeding to Mill
- Improves bulk density at feed entry
- Improves Drainage of Superficial Juice through Nozzles

### Cane Cutter



- Heavy Duty
- Heavy Anti Friction Bearing
- Balanced Rotor
- Special Alloy Hard Faced Knives

### Cane Fibrizer & Cane Shredder

- Preparatory Index 85+ & 90+ with long Fibre
- Swing type Hammers with replaceable Tips
- Provision of Tramp Iron Separator
- Short Anvil Plate
- Low Nip Angle



### Re-absorption Control Device

- Reduction of moisture of respective mill by about 1%
- Reduction of re-absorption of respective mill by about 70%
- Device is installed at the discharge side of Mill
- The re-absorption is controlled by hydraulic mechanism

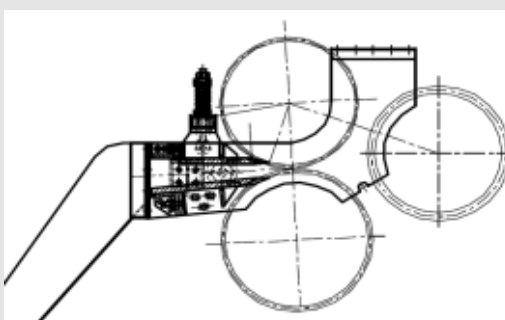
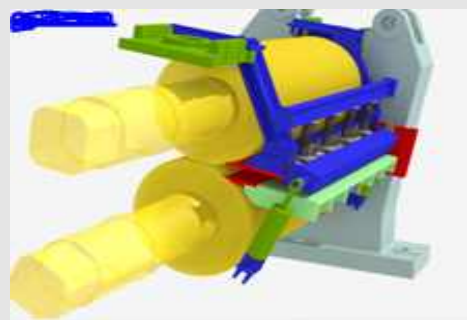

### Few of our Clients

- Kanoria Sugar
- Kesar Enterprises Ltd.
- Walchandnagar Industries Ltd.-Various Projects
- Thyssen Krupp India Ltd.
- ISGEC Heavy Engineering Ltd.-Various Projects
- Balampur Chinni Mills - Kumbhi
- Balampur Chinni Mills - Rozagaon
- Superior Food Grains Pvt. Ltd. - Unn

## ENERGY DIVISION

### Planetary Gear Drive

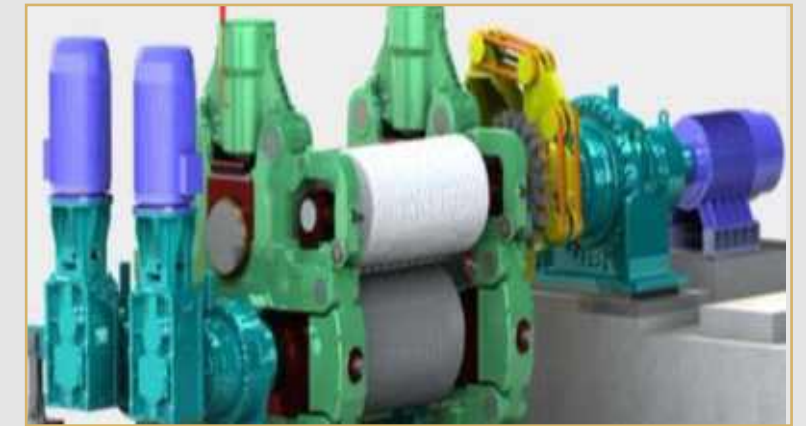
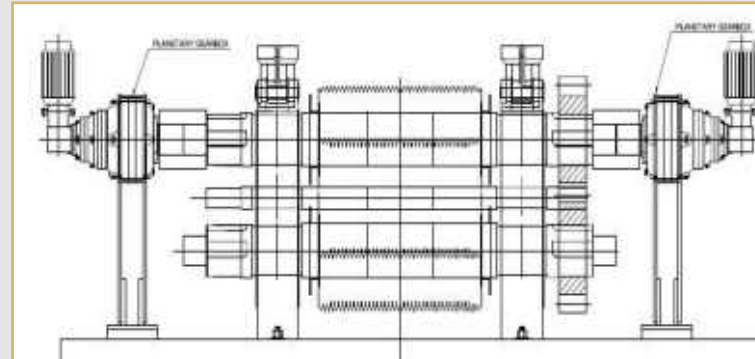

Upto 20% saving in Power

### Bagasse Dryer



Upto 10 units reduction  
in Bagasse Moisture

### Project & Sugar Plant Consulting



#### Our Strengths

- Sugar plant modernization & expansion programme
- Reduction in Milling and Boiling House losses
- Energy efficient planning and Execution
- Down time reduction strategy
- Project execution in EPCC plan

#### Our Patrons

- Kesar Sugar
- Dalmia Sugar
- L.H. Sugar
- K.M. Sugar
- Tikaula Sugar
- Olam Agro India Ltd.
- Dwarikesh Sugars
- Dewan Sugar
- Naraingarh Sugar
- Fiji Sugar Corporation
- Philippines Sugar Units
- SBEC Sugars
- RBNS Sugar
- Saraswati Sugar Mills
- Chadha Sugar
- SNJ Sugars & Products Ltd.



P. S. SRIVASTAVA